

**STARR WHITEHOUSE**  
Landscape Architects  
and Planners PLLC

# Manhattan Greenway Harlem River

Sub-project Area 2  
Preliminary Design

September 7, 2023



**STARR WHITEHOUSE**  
Landscape Architects  
and Planners PLLC

# PROJECT CONTEXT



Sub-project 2 is one of three sub-project areas in an overall waterfront bulkhead reconstruction project that includes the areas from 125th Street to 145th Street and from 154th Street to Swindlers Cove.

The scope of this concept plan includes:

- In-kind replacement of areas within Sub-project 2 that will be disturbed by the bulkhead reconstruction
- New tree plantings throughout Sub-project 2



## MGHR | Project Location

September 7, 2023



**LANGAN**



**STARR WHITEHOUSE**  
Landscape Architects  
and Planners PLLC



NEIGHBORHOOD

1/4 mile

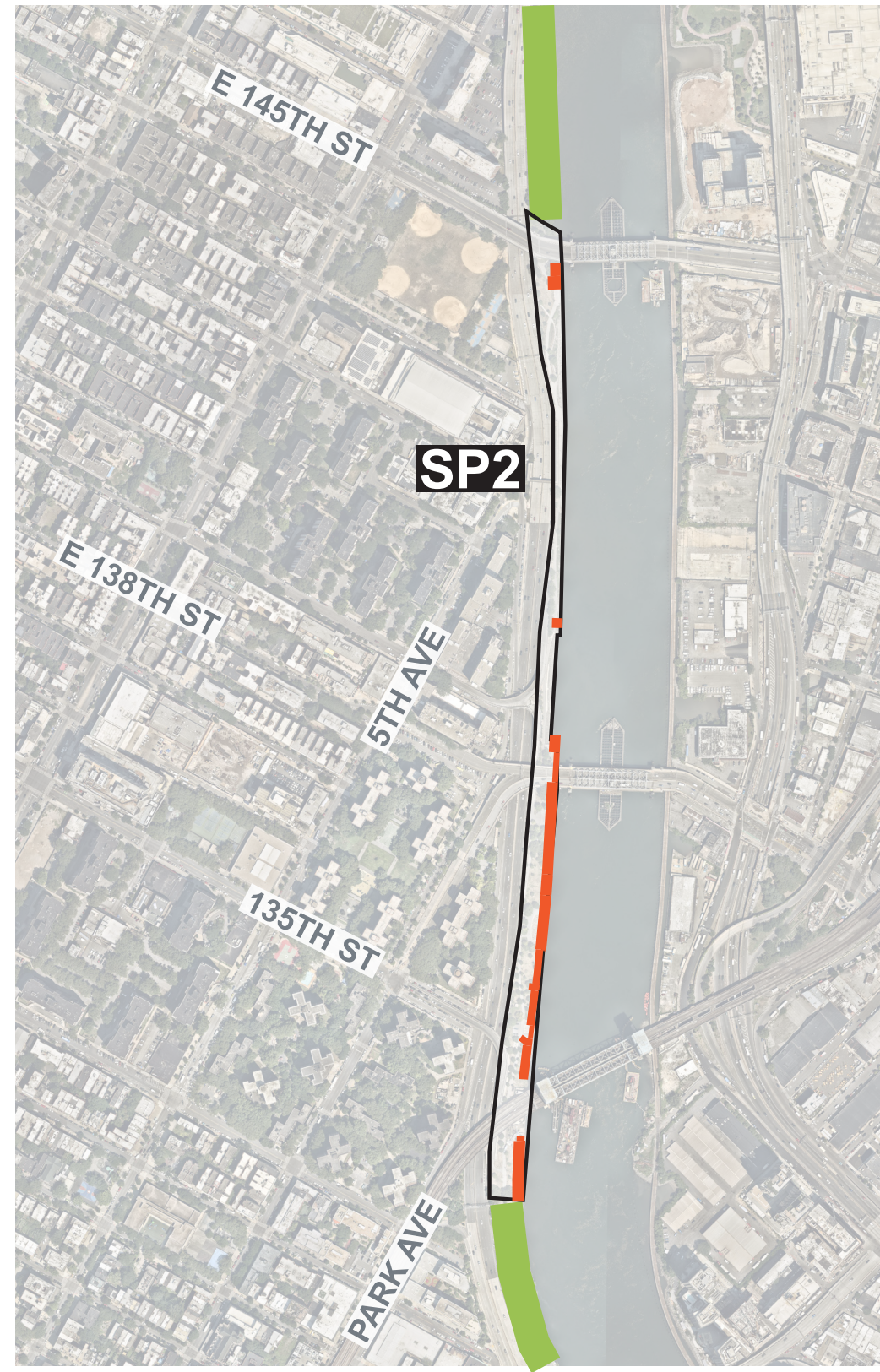

SITE

200'

- 6.7 acres of park area
- 1.6 acres of disturbed area by reconstruction behind park surface

Disturbed Area by Bulkhead Reconstruction

# MGHR | Project Location

September 7, 2023



STARR WHITEHOUSE  
Landscape Architects  
and Planners PLLC

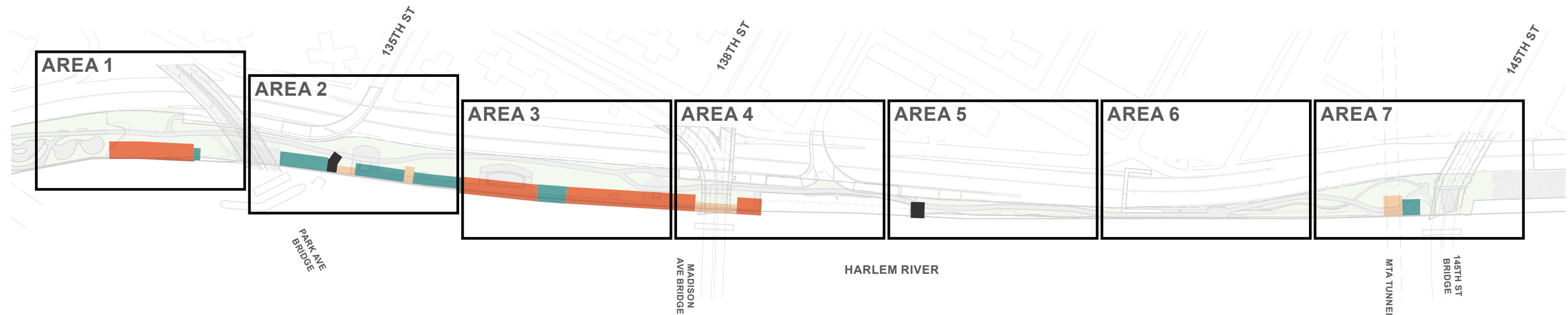

**LEGEND**

- ANCHORED BULKHEAD
- HIGH LEVEL PLATFORM
- CONCRETE RETAINING WALL
- DEP STRUCTURE

**Anchored Bulkhead:** New sheetpile will be installed in front of existing timber cribbing. Tie rods anchor sheetpile to a concrete deadman. New fill will be placed on top of timber cribbing and new bulkhead system.

**High Level Platform:** New piles will be constructed and a new platform will be constructed on top of the piles.

**Concrete Retaining Wall:** New piles will be constructed and a new L-shape concrete retaining wall will be constructed on top of the piles.

- Finish grade will match existing grade, which averages +7' to +9' NAVD88 across sub-project 2. Engineered for future fill for elevation +17' NAVD88.



**MGHR | Bulkhead Type**

September 7, 2023



**STARR WHITEHOUSE**  
Landscape Architects  
and Planners PLLC

# EXISTING CONDITION

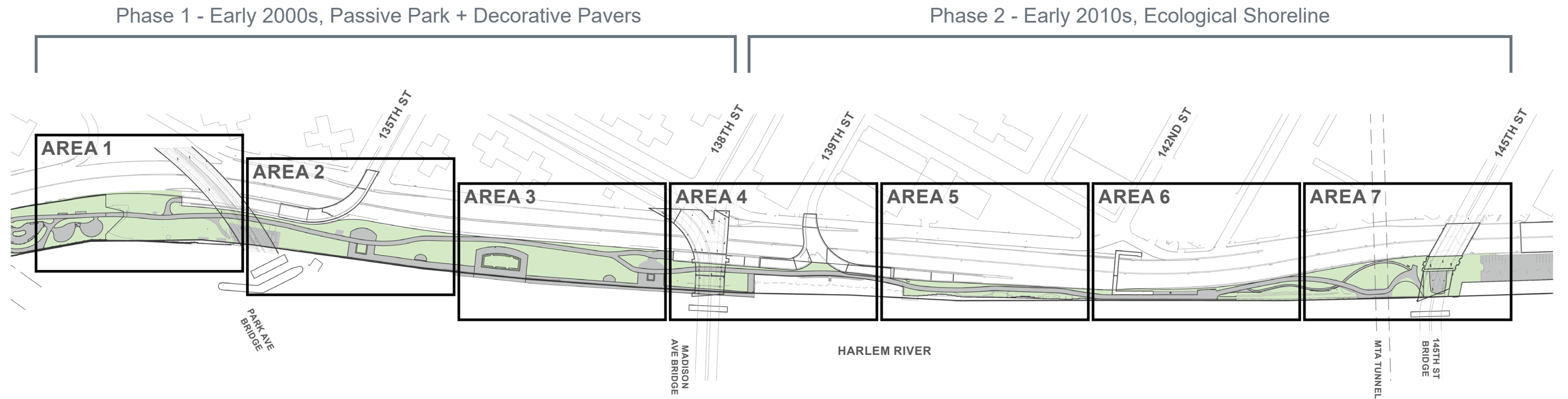

LEGEND

 ENLARGED PLAN AREA



# MGHR | Area Key

September 7, 2023



STARR WHITEHOUSE  
Landscape Architects  
and Planners PLLC



1 - View looking south from 135th St pedestrian bridge



2 - View looking north to existing Hudson River Park bikeway







1 - View looking southeast from main plaza



2 - View looking south from esplanade





1 - View looking north from inner tidal zone 2



2 - View looking south from under 145th St bridge

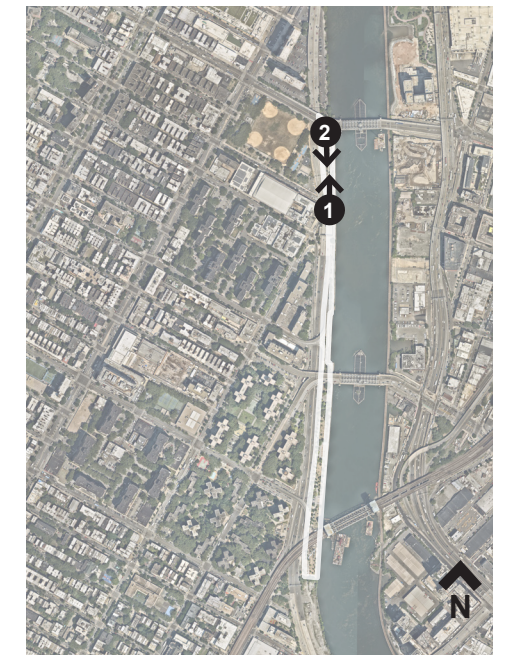

# PRELIMINARY DESIGN

## Replacement of Shoreline, Esplanade, and Adjacent Areas

- Extend life-cycle of the park
- Safety
  - Sea-rail
  - Stability of esplanade
- Utilities
  - Restore water service to drinking fountains
- Plaza areas
  - Enhance decorative paving and plantings
- Furnishings
  - Companion seating
- Trees
  - Replace all tree impacted by bulkhead reconstruction
  - Resilient plant palette

KEY MAP



LEGEND

- LAWN
- SPECIAL PAVING
- ASPHALT PAVEMENT
- ASPHALT HEX PAVER
- CONCRETE
- LIMIT OF WORK
- EXISTING TREE TO PROTECT AND REMAIN
- TREE TO BE REMOVED
- APPROXIMATE AREA DISTURBED BY BULKHEAD RECONSTRUCTION



MGHR | Existing Condition | Area 1

September 7, 2023



KEY MAP

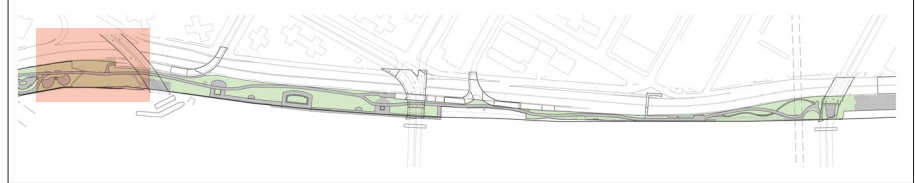

LEGEND

- LAWN
- SPECIAL PAVING
- ASPHALT PAVEMENT
- ASPHALT HEX PAVER
- CONCRETE
- LIMIT OF WORK
- EXISTING TREE
- PROPOSED TREE
- 8' 1964 WORLD'S FAIR BENCHES AND COMPANION SEATING
- APPROXIMATE AREA DISTURBED BY BULKHEAD RECONSTRUCTION



MGHR | Proposed Plan | Area 1

July 31, 2023



KEY MAP

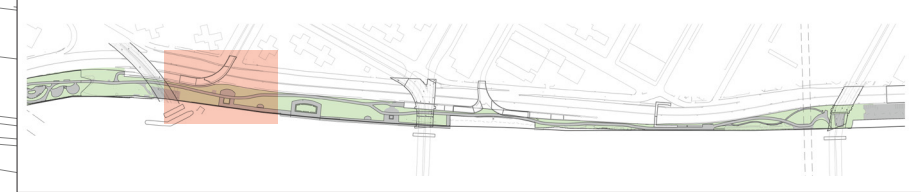

LEGEND

- LAWN
- SPECIAL PAVING
- ASPHALT PAVEMENT
- ASPHALT HEX PAVER
- CONCRETE
- LIMIT OF WORK
- EXISTING TREE TO PROTECT AND REMAIN
- TREE TO BE REMOVED
- APPROXIMATE AREA DISTURBED BY BULKHEAD RECONSTRUCTION



MGHR | Existing Condition | Area 2

September 7, 2023



KEY MAP

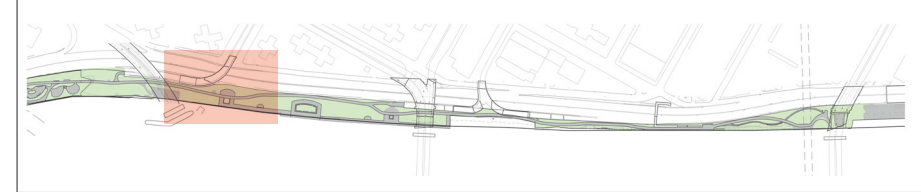

LEGEND

- LAWN
- SPECIAL PAVING
- ASPHALT PAVEMENT
- ASPHALT HEX PAVER
- CONCRETE
- LIMIT OF WORK
- EXISTING TREE
- PROPOSED TREE
- 8' 1964 WORLD'S FAIR BENCHES AND COMPANION SEATING
- APPROXIMATE AREA DISTURBED BY BULKHEAD RECONSTRUCTION



MGHR | Proposed Plan | Area 2

September 7, 2023



STARR WHITEHOUSE  
Landscape Architects  
and Planners PLLC



KEY MAP

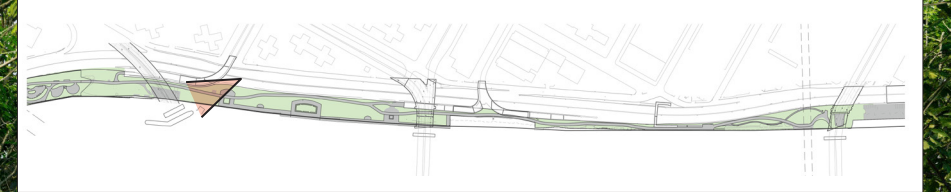

MGHR | Rendering | Area 2

June 30, 2023



STARR WHITEHOUSE  
Landscape Architects  
and Planners PLLC

KEY MAP

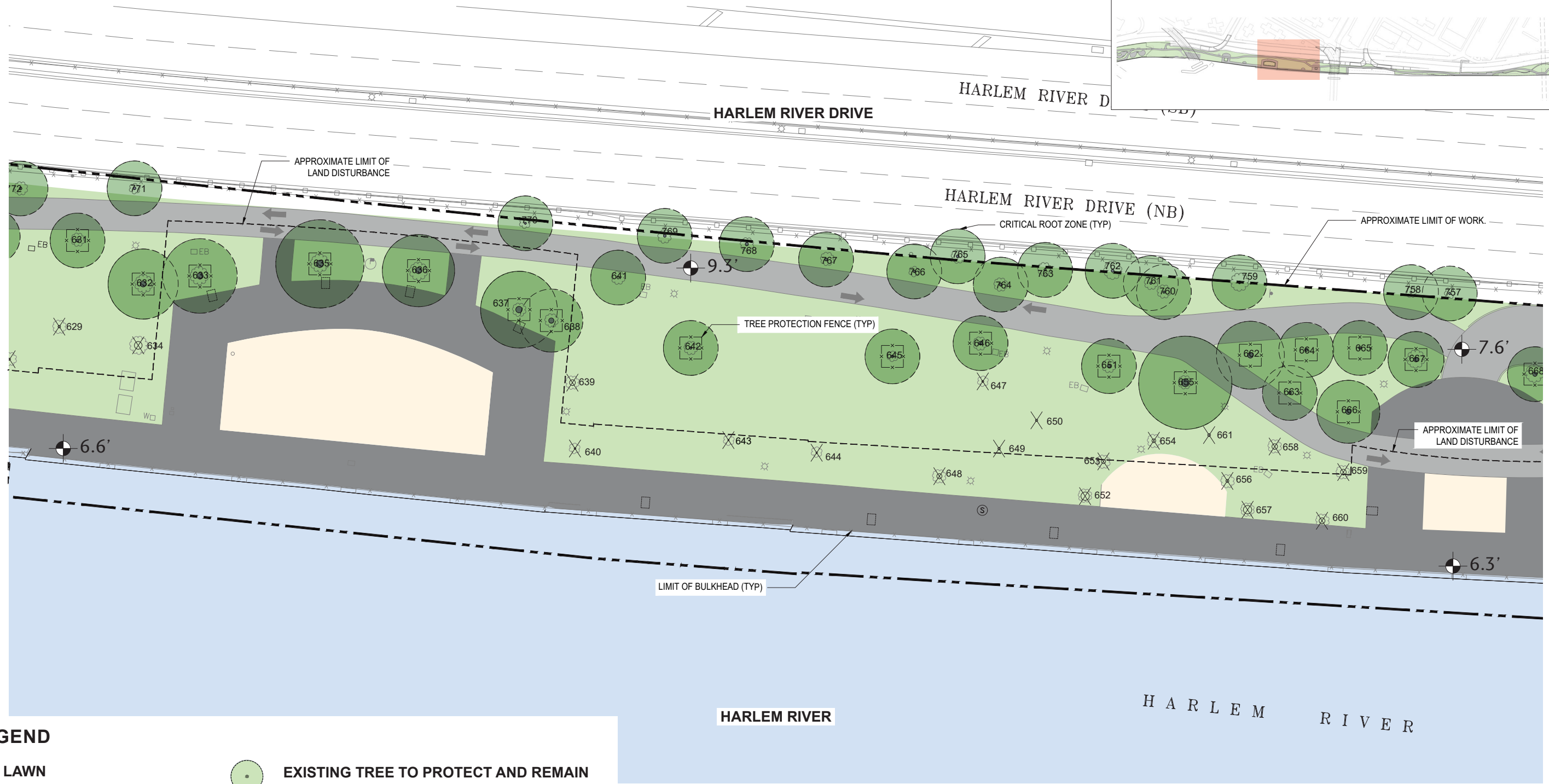
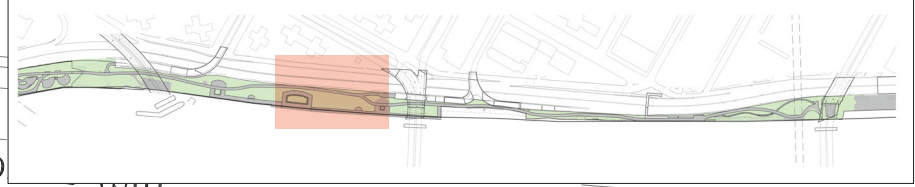

LEGEND

- LAWN
- SPECIAL PAVING
- ASPHALT PAVEMENT
- ASPHALT HEX PAVER
- CONCRETE
- LIMIT OF WORK
- EXISTING TREE TO PROTECT AND REMAIN
- TREE TO BE REMOVED
- APPROXIMATE AREA DISTURBED BY BULKHEAD RECONSTRUCTION



MGHR | Existing Condition | Area 3

September 7, 2023



KEY MAP

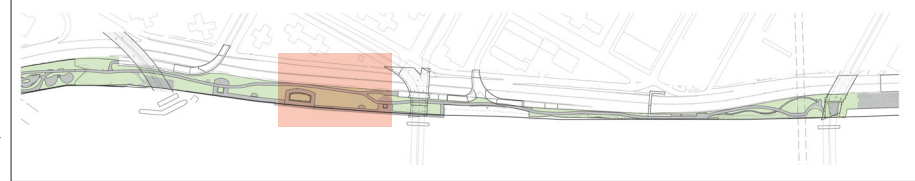

LEGEND

- LAWN
- SPECIAL PAVING
- ASPHALT PAVEMENT
- ASPHALT HEX PAVER
- CONCRETE
- LIMIT OF WORK
- EXISTING TREE
- PROPOSED TREE
- 8' 1964 WORLD'S FAIR BENCHES AND COMPANION SEATING
- APPROXIMATE AREA DISTURBED BY BULKHEAD RECONSTRUCTION



MGHR | Proposed Plan | Area 3

September 7, 2023



STARR WHITEHOUSE  
Landscape Architects  
and Planners PLLC

KEY MAP

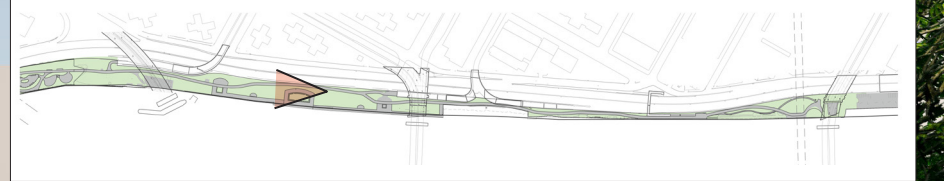

MGHR | Rendering | Area 3

June 30, 2023



LANGAN



STARR WHITEHOUSE  
Landscape Architects  
and Planners PLLC

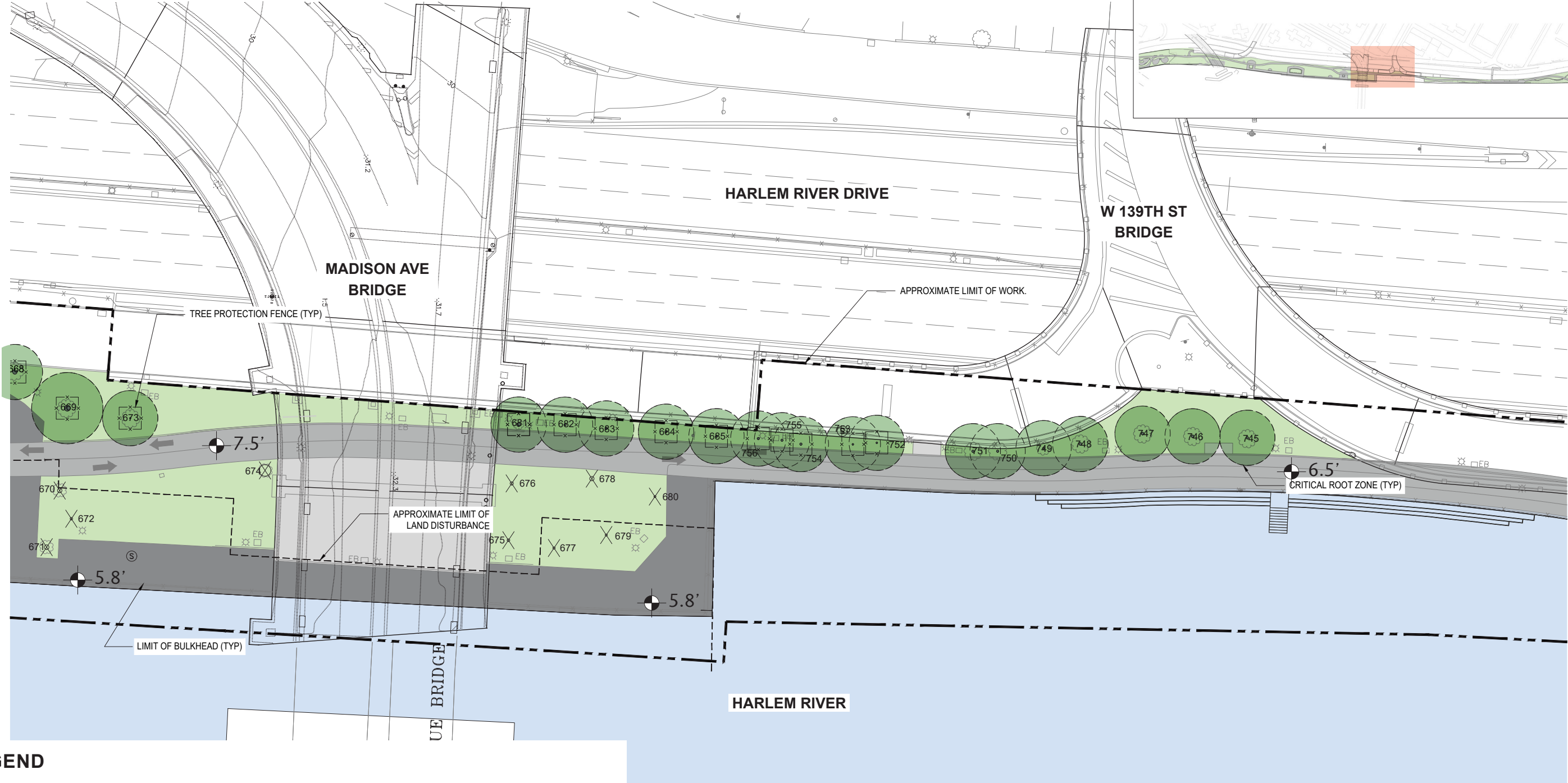
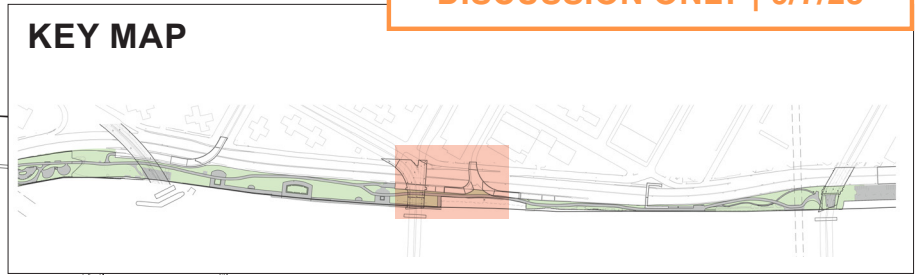

**LEGEND**

- LAWN
- SPECIAL PAVING
- ASPHALT PAVEMENT
- ASPHALT HEX PAVER
- CONCRETE
- LIMIT OF WORK
- EXISTING TREE TO PROTECT AND REMAIN
- TREE TO BE REMOVED
- APPROXIMATE AREA DISTURBED BY BULKHEAD RECONSTRUCTION



**MGHR | Existing Condition | Area 4**

September 7, 2023



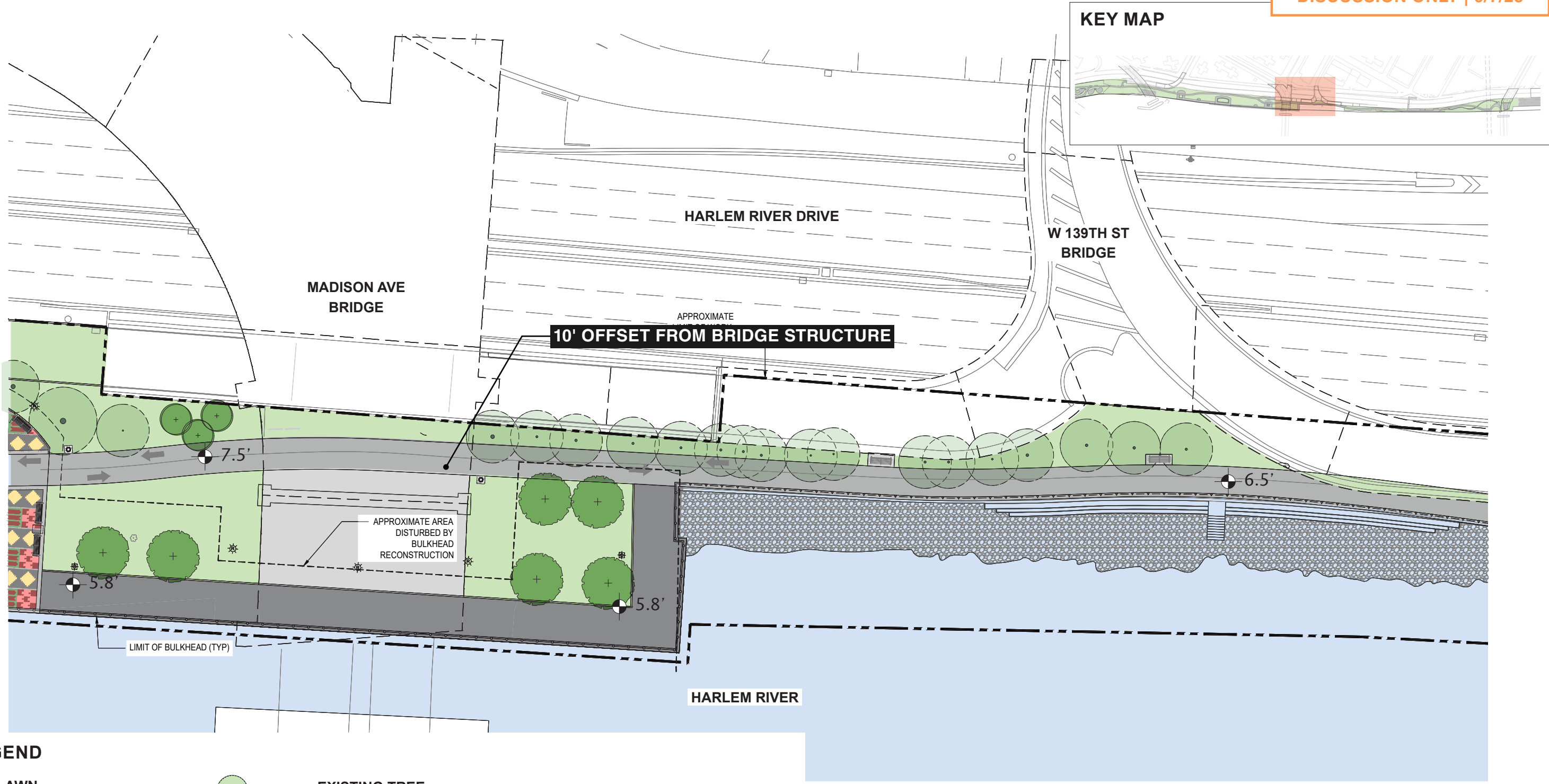

**LEGEND**

- LAWN
- SPECIAL PAVING
- ASPHALT PAVEMENT
- ASPHALT HEX PAVER
- CONCRETE
- LIMIT OF WORK
- EXISTING TREE
- PROPOSED TREE
- 8' 1964 WORLD'S FAIR BENCHES AND COMPANION SEATING
- APPROXIMATE AREA DISTURBED BY BULKHEAD RECONSTRUCTION



**MGHR | Proposed Plan | Area 4**

September 7, 2023



NYC / EDC



NYC Parks



LANGAN



STARR WHITEHOUSE  
Landscape Architects  
and Planners PLLC

KEY MAP

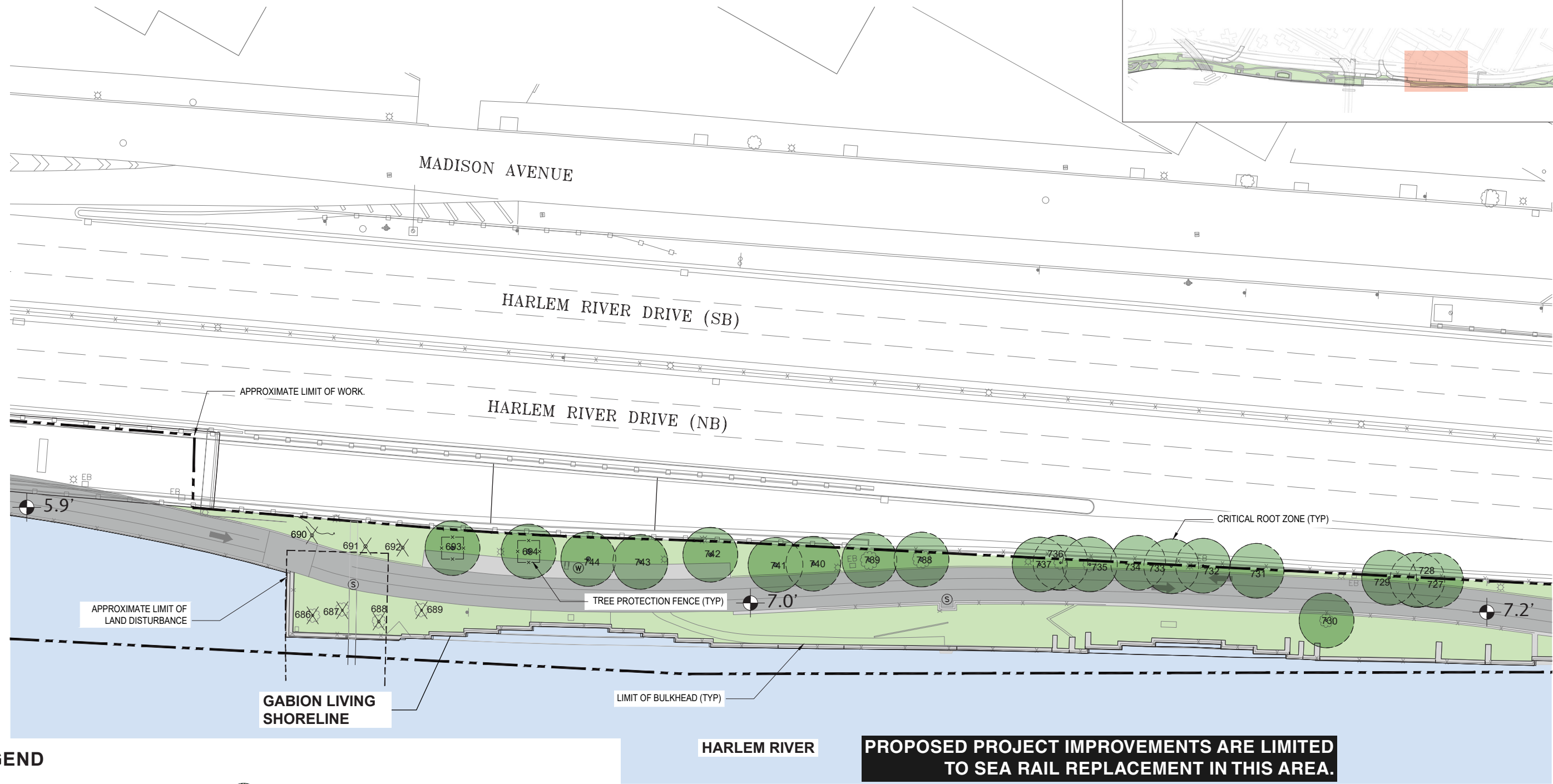
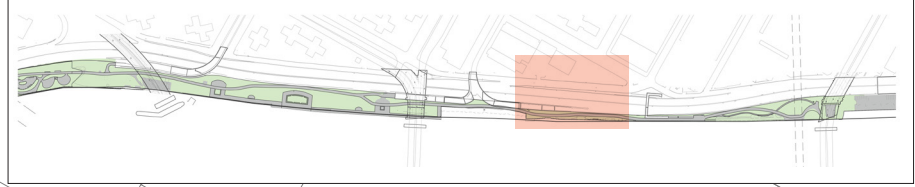

LEGEND

- LAWN
- SPECIAL PAVING
- ASPHALT PAVEMENT
- ASPHALT HEX PAVER
- CONCRETE
- LIMIT OF WORK
- EXISTING TREE TO PROTECT AND REMAIN
- TREE TO BE REMOVED
- APPROXIMATE AREA DISTURBED BY BULKHEAD RECONSTRUCTION



MGHR | Existing Condition | Area 5

September 7, 2023



KEY MAP

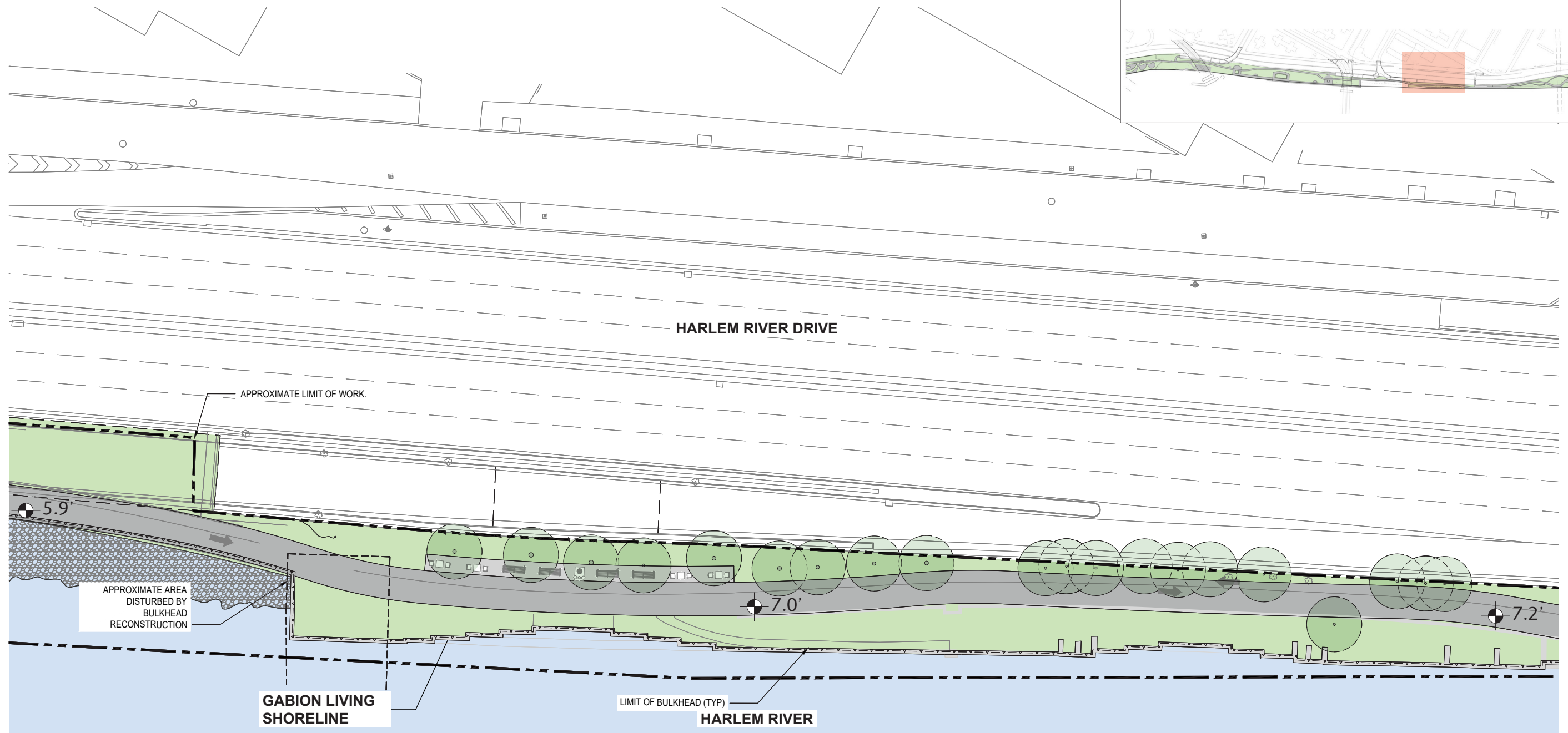
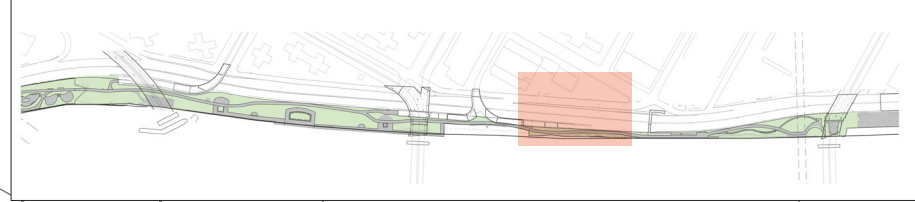

**PROPOSED PROJECT IMPROVEMENTS ARE LIMITED TO SEA RAIL REPLACEMENT IN THIS AREA.**

LEGEND

- LAWN
- SPECIAL PAVING
- ASPHALT PAVEMENT
- ASPHALT HEX PAVER
- CONCRETE
- LIMIT OF WORK
- EXISTING TREE
- PROPOSED TREE
- 8' 1964 WORLD'S FAIR BENCHES AND COMPANION SEATING
- APPROXIMATE AREA DISTURBED BY BULKHEAD RECONSTRUCTION



MGHR | Proposed Plan | Area 5

September 7, 2023



STARR WHITEHOUSE  
Landscape Architects  
and Planners PLLC



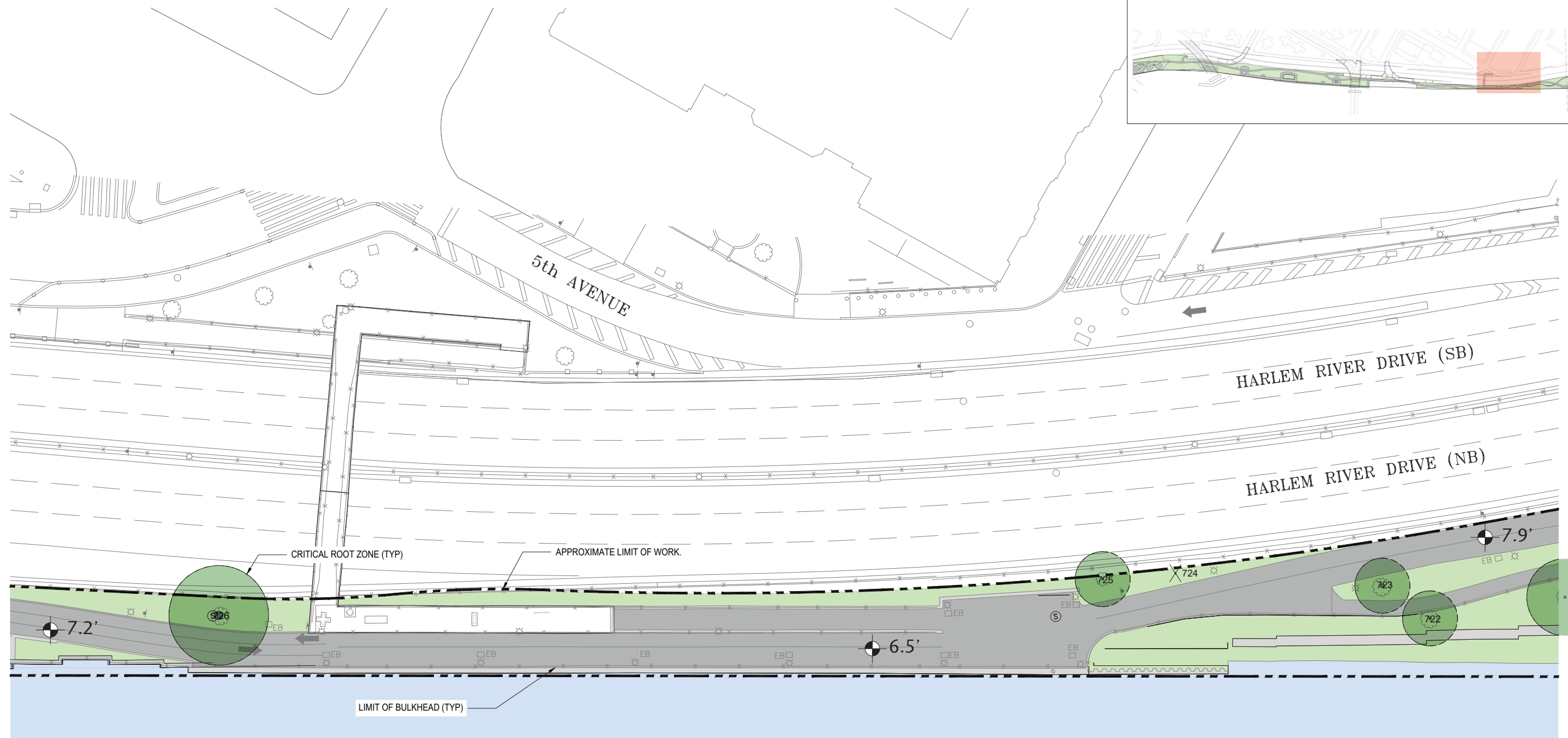
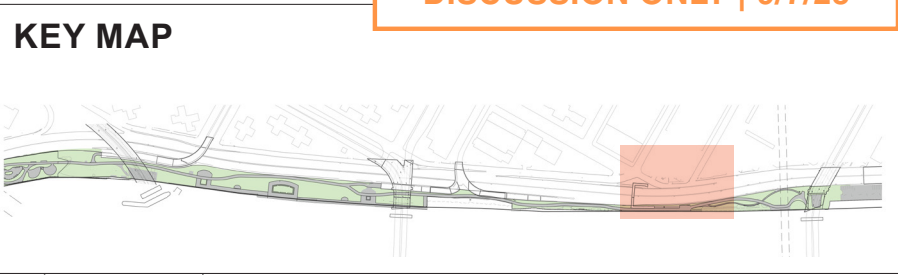

**PROPOSED PROJECT IMPROVEMENTS ARE LIMITED TO SEA RAIL REPLACEMENT IN THIS AREA.**

**LEGEND**

- LAWN
- SPECIAL PAVING
- ASPHALT PAVEMENT
- ASPHALT HEX PAVER
- CONCRETE
- LIMIT OF WORK
- EXISTING TREE TO PROTECT AND REMAIN
- TREE TO BE REMOVED
- APPROXIMATE AREA DISTURBED BY BULKHEAD RECONSTRUCTION



**MGHR | Existing Condition | Area 6**

September 7, 2023



KEY MAP

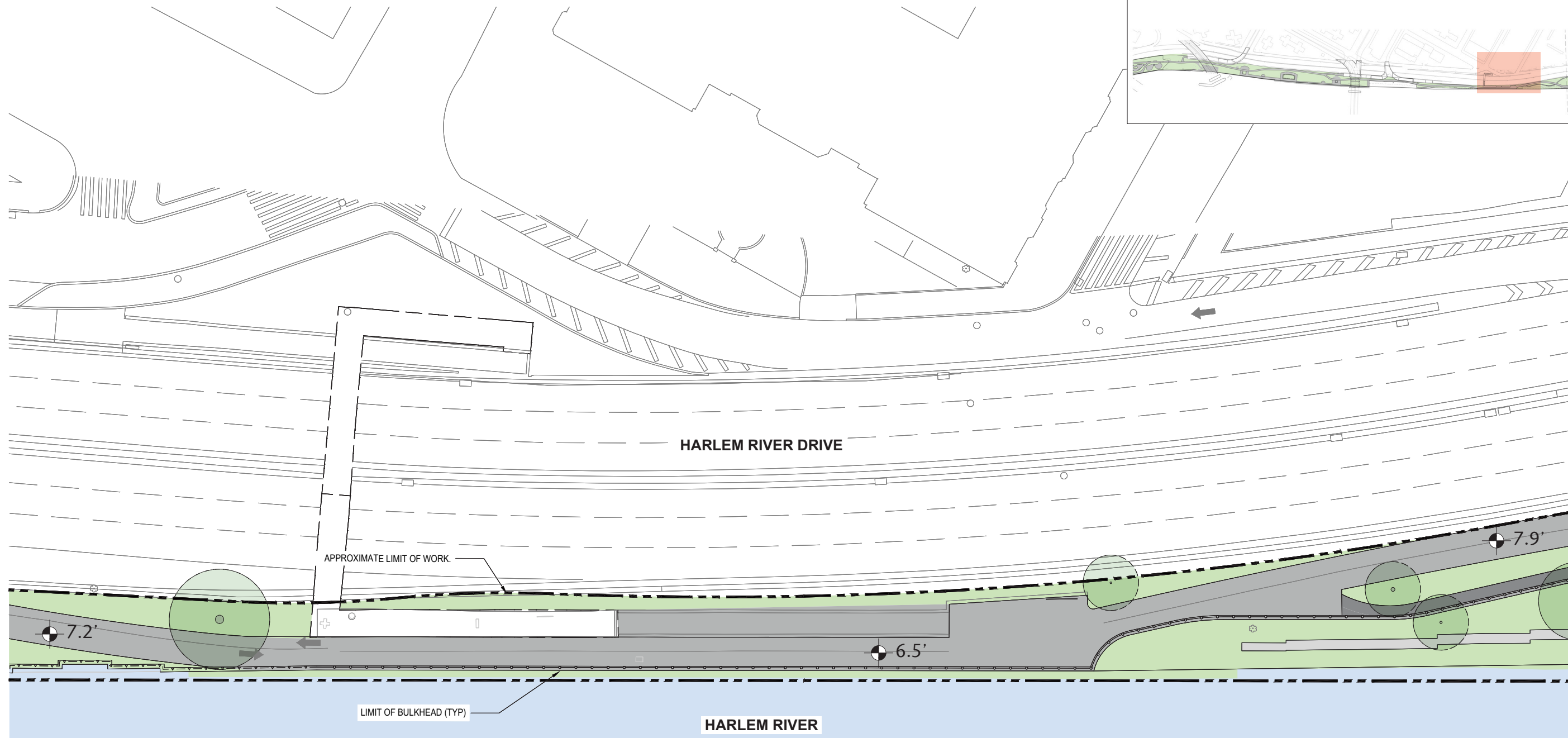
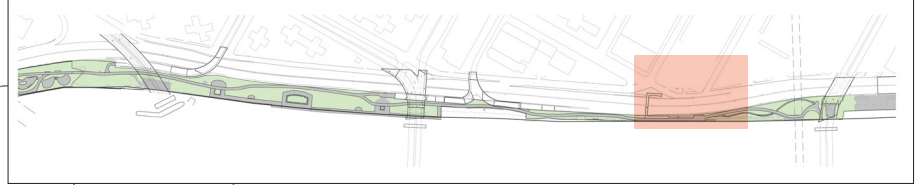

**PROPOSED PROJECT IMPROVEMENTS ARE LIMITED TO SEA RAIL REPLACEMENT IN THIS AREA.**

**LEGEND**

- LAWN
- SPECIAL PAVING
- ASPHALT PAVEMENT
- ASPHALT HEX PAVER
- CONCRETE
- LIMIT OF WORK
- EXISTING TREE
- PROPOSED TREE
- 8' 1964 WORLD'S FAIR BENCHES AND COMPANION SEATING
- APPROXIMATE AREA DISTURBED BY BULKHEAD RECONSTRUCTION



**MGHR | Proposed Plan | Area 6**

September 7, 2023



KEY MAP

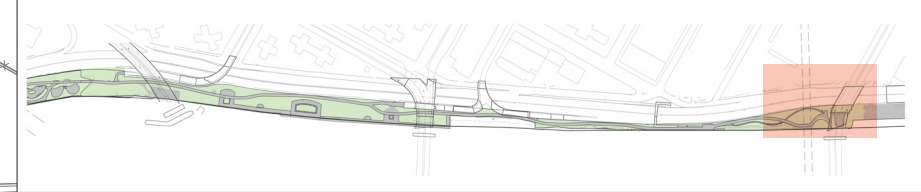

LEGEND

- LAWN
- SPECIAL PAVING
- ASPHALT PAVEMENT
- ASPHALT HEX PAVER
- CONCRETE
- LIMIT OF WORK
- EXISTING TREE TO PROTECT AND REMAIN
- TREE TO BE REMOVED
- APPROXIMATE AREA DISTURBED BY BULKHEAD RECONSTRUCTION



MGHR | Existing Condition | Area 7

September 7, 2023

KEY MAP

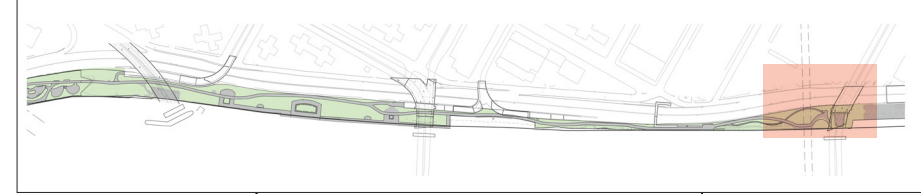

LEGEND

- LAWN
- SPECIAL PAVING
- ASPHALT PAVEMENT
- ASPHALT HEX PAVER
- CONCRETE
- LIMIT OF WORK
- EXISTING TREE
- + PROPOSED TREE
- 8' 1964 WORLD'S FAIR BENCHES AND COMPANION SEATING
- APPROXIMATE AREA DISTURBED BY BULKHEAD RECONSTRUCTION



MGHR | Proposed Plan | Area 7

September 7, 2023



STARR WHITEHOUSE  
Landscape Architects  
and Planners PLLC

# APPENDIX

ASPHALT PAVEMENT - MULTI-PURPOSE PATHWAY WITH  
GREENWAY SYMBOLS AND SIGNAGE



HEXAGONAL AND RECTANGULAR ASPHALT  
BLOCK PAVEMENT - ESPLANADE, LANDSCAPE  
PATH IN AREA 6 AND 7, AND IN PLAZA



HANOVER | A80027  
Ground Tudor Finish

HANOVER | A80043  
Ground Tudor Finish

DECORATIVE PAVING - COLORED CONCRETE PANELS AND  
BANDS - TO BE REPLACED IN-KIND

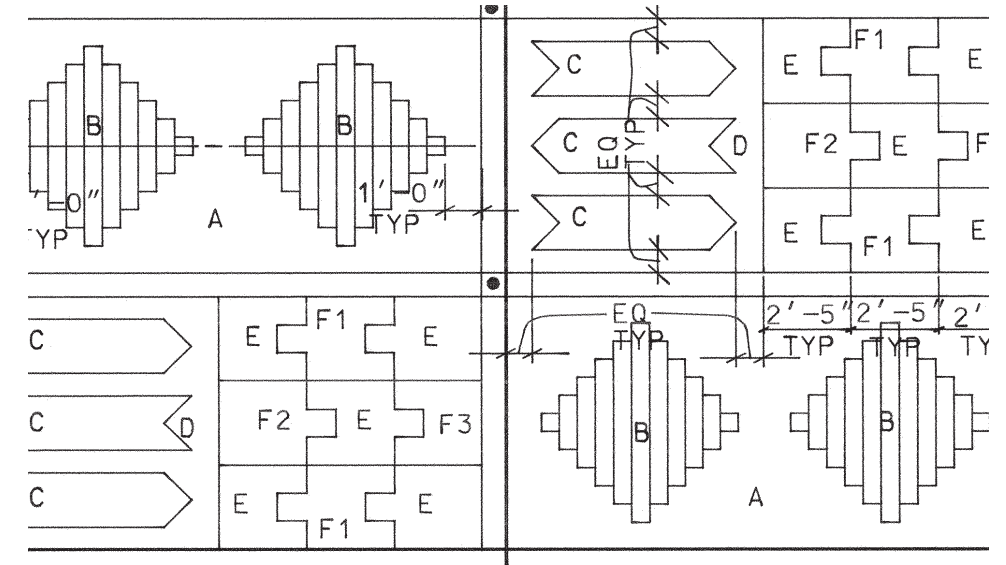

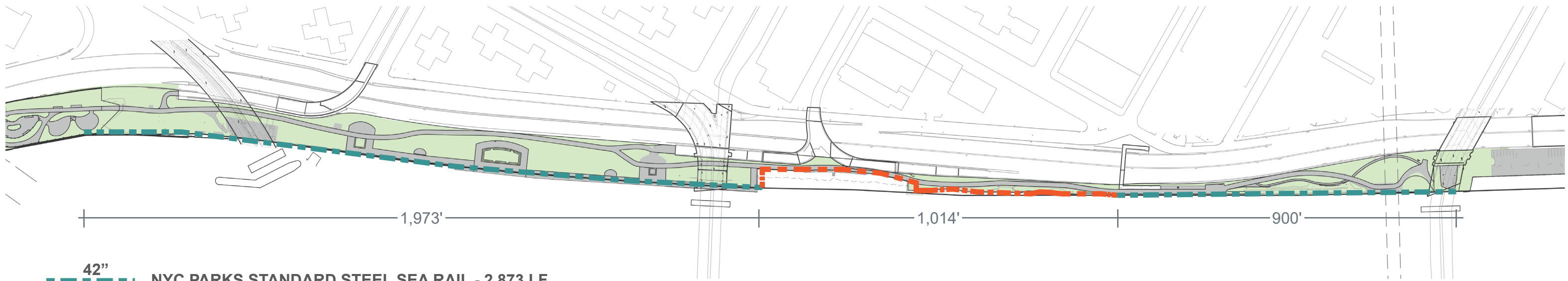

- - - 42" NYC PARKS STANDARD STEEL SEA RAIL - 2,873 LF
- - - 42" NYC PARKS STANDARD ALUMINIUM SAFETY RAILING - 1,014 LF

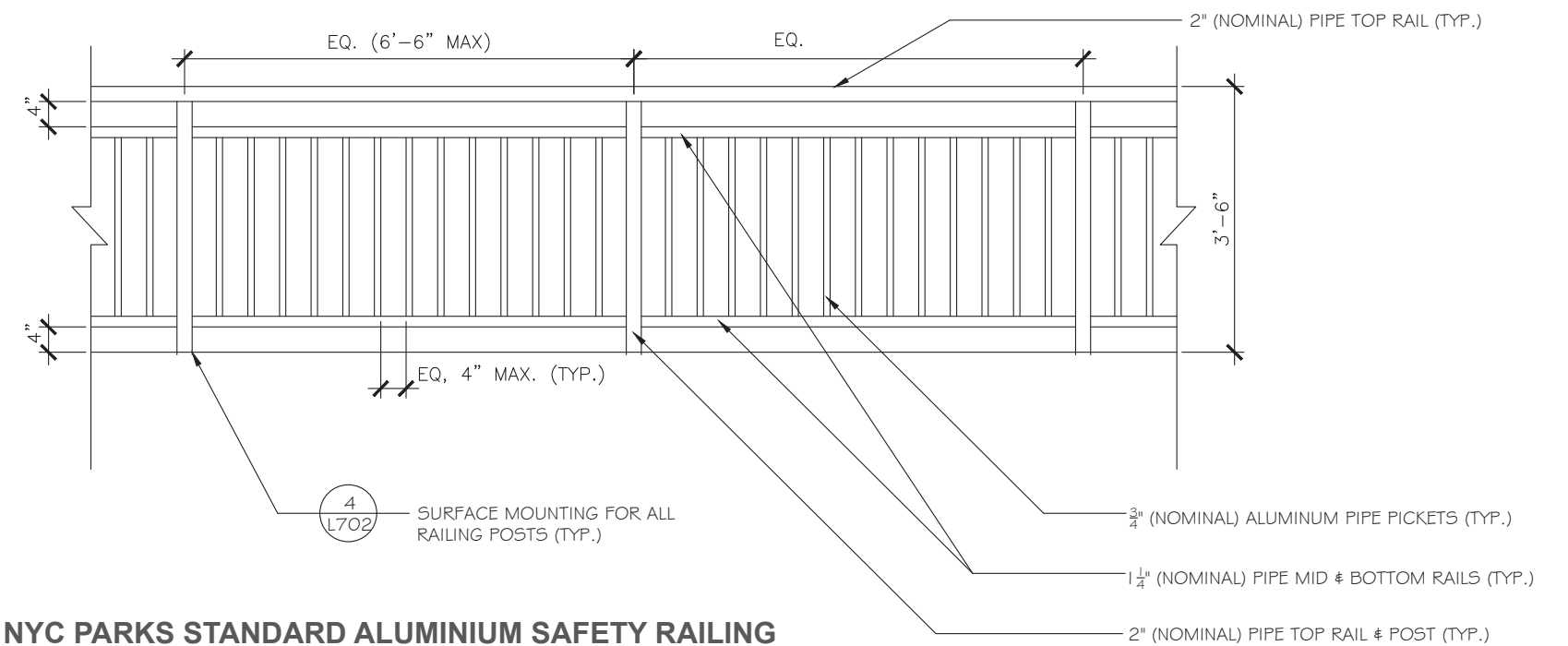
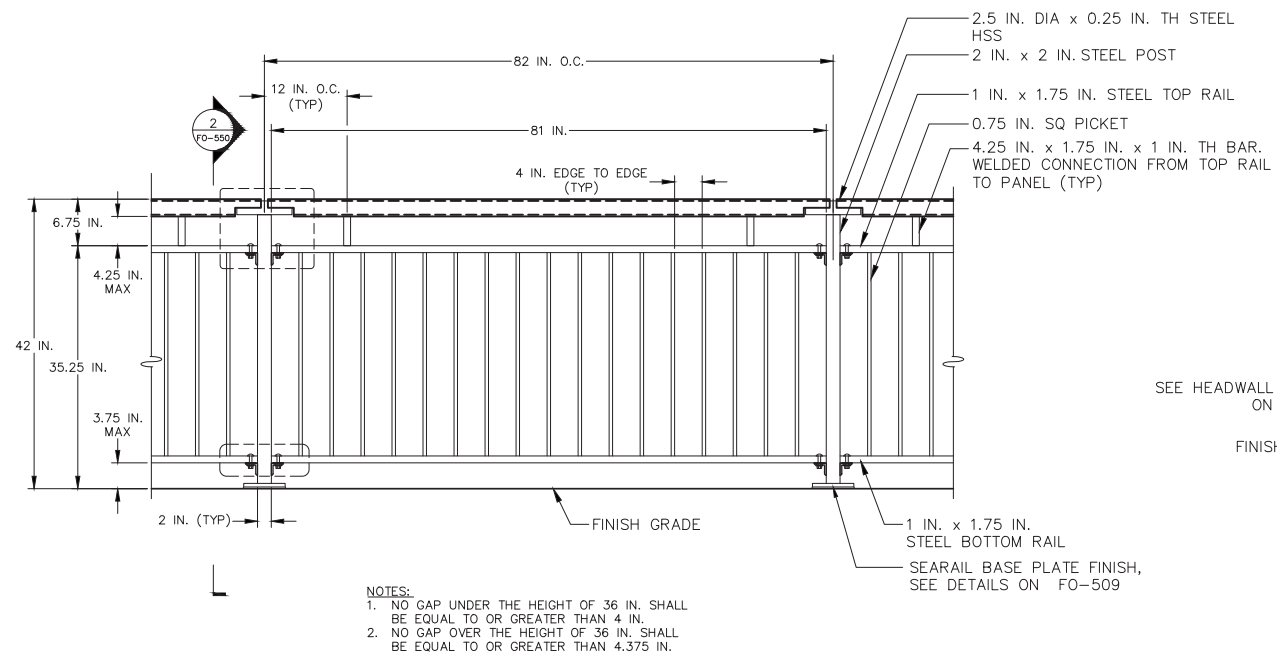
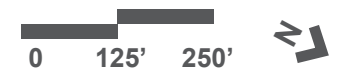

NYC PARKS STANDARD STEEL SEA RAIL

NYC PARKS STANDARD ALUMINIUM SAFETY RAILING



SEATING (x60)  
1964 World's Fair Bench



DRINKING FOUNTAIN (x3)  
Most Dependable Fountains



TRASH RECEPTACLE (x22)  
NYC Parks Typ.



EXISTING FLAG POLE WITH  
YARDARM AND GRANITE BASE (x1)  
To be removed, refurbished, and  
reset in the original location



CANOPY TREES



*Quercus rubra* Red Oak



*Quercus palustris* Pin Oak



*Celtis occidentalis* Hackberry



*Juniperus virginiana* Eastern Red Cedar

UNDERSTORY TREES



*Cercis canadensis* Eastern Redbud



*Amelanchier laevis* Snowcloud Allegheny  
Serviceberry



*Ilex opaca* American Holly

Proposed Tree planting palette for SP2 design.

CITY EDGE PLANTING



*Comptonia peregrina* Sweetfern



*Morella caroliniensis* Bayberry



*Prunus maritima* Beach Plum



*Rhus typhina* Staghorn Sumac

ENTRANCE PLANTING



*Ilex verticillata* Winterberry



*Itea virginica* Virginia Sweetspire



*Rosa rugosa* Rugosa Rose



*Clethra alnifolia* Sweet Pepperbush

FRAMING PLANTING



*Ilex glabra* 'Compacta' Inkberry



*Itea virginica* Virginia Sweetspire



*Rosa carolina* Carolina Rose

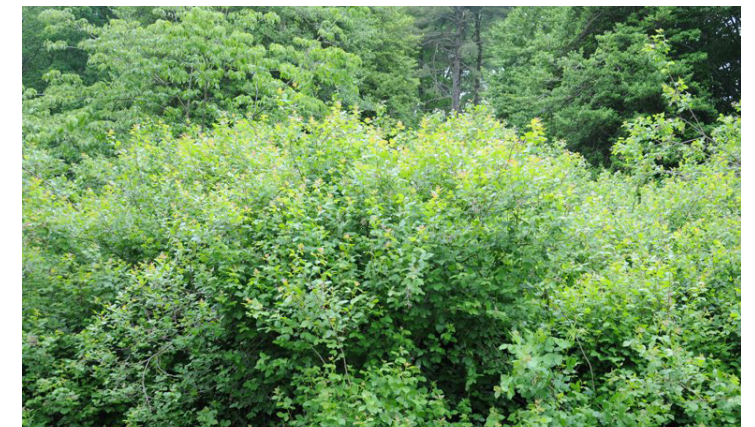

*Rhus aromatica* Fragrant Sumac

Proposed groundcover planting palette for SP2 design.

**MGHR | Planting | Groundcover / Perennials**

September 7, 2023



**STARR WHITEHOUSE**  
Landscape Architects  
and Planners PLLC

**STARR WHITEHOUSE**  
Landscape Architects  
and Planners PLLC

# Manhattan Greenway Harlem River

Sub-project Area 2  
Preliminary Design

September 7, 2023



**STARR WHITEHOUSE**  
Landscape Architects  
and Planners PLLC